

**Metal Seated, Non-Rising Stem Gate Valve**

**Metal Seated:**

Gunmetal Seating allows greater wear & longer services life further guarantee drop tight closure under full pressure.

**Design:**

- The design allows replacement of the sealing system when the valve under pressure and in fully open position.
- Gunmetal Thrust Collar provides stem guidance and low friction bearing on opening and closing torque.
- Superior Stem made from Stainless Steel 431S29 promises more operation cycle.

**Technical Specification:**

- Standard : BS EN 1171: 2002
- Nominal Size : DN 350 – DN 1000
- Nominal Pressure : PN 16
- Drilling Flange : BS EN 1092-2, PN16
- Protection : Cold Applied Epoxy Coated or Fusion Bonded Epoxy
- Working Temperature : Maximum 70°C

Product has been listed with



Metal Seat with Captop



Metal Seat Bypass with Gearing

Metal Seat with Gearing

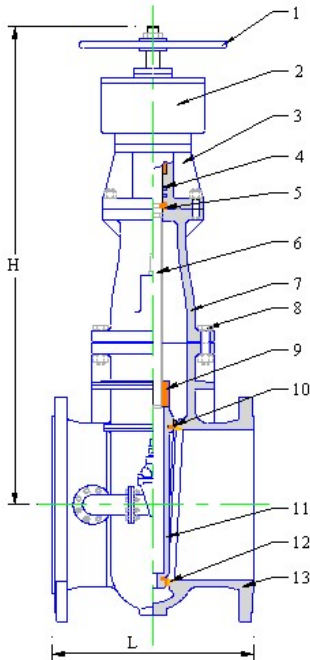

**Material Specification:**

No.	Component	Reference Standard
1.	Handwheel	Ductile Iron, BS EN 1563, EN-GJS-500-7
2.	Gear Housing	Ductile Iron, BS EN 1563, EN-GJS-500-7
3.	Mounting Flange	Ductile Iron, BS EN 1563, EN-GJS-500-7
4.	Gasket	EPDM, BS EN 681-1, Type WA
5.	Thrust Collar	Gunmetal, BS 1400, LG2
6.	Stem	Stainless Steel, BS 970-1, 431S29
7.	Bonnet	Ductile Iron, BS EN 1563, EN-GJS-500-7
8.	Bolt and Nut	Stainless Steel, BS 970-1, 304S31
9.	Wedge Nut	Gunmetal, BS 1400, LG2
10.	Wedge Seal Ring	Gunmetal, BS 1400, LG2
11.	Wedge	Ductile Iron, BS EN 1563, EN-GJS-500-7
12.	Body Seal Ring	Gunmetal, BS 1400, LG2
13.	Body	Ductile Iron, BS EN 1563, EN-GJS-500-7

**Dimension Specification (mm):**

DN	350	400	450	500	600	700	800	900	1000
L	381	406	432	457	508	610	660	711	813
H (Max)	1150	1275	1350	1500	1700	1800	2000	2400	2500



**TPLI INDUSTRIES SDN BHD**

PLOT 30 – 32, JALAN LOGAM 1,  
KAWASAN PERINDUSTRIAN KAMUNTING III,  
34600 KAMUNTING,  
PERAK DARUL RIDZUAN,  
MALAYSIA.

MARKETING OFFICE  
TEL : (605) – 8958001/2  
FAX : (605) - 8958000  
EMAIL : tplimc@gmail.com  
WEBSITE : http://www.tpli.com.my

